

Sensormatic® Pro-Max® Plus Ultra•Max® Acousto-Magnetic Detection System



Description

The Sensormatic Pro-Max Plus System couples advanced digital technology with Ultra•Max Acousto-Magnetic capability to deliver superb wide exit anti-shoplifting protection.

Used by some of the world's leading retailers, the Pro-Max Plus Electronic Article Surveillance (EAS) System can cover exits up to 4.8 m (15.7 ft.) wide using only two pedestals. Multiple pedestals can cover wider exits.

The system is especially popular with mall retailers, home centers, discount retailers, and others who value reliable, high detection performance.

Features

- **Performance.** The Ultra*Post® Plus Controller delivers superb detection performance across wide exits.
- **All weather design.** The Pro-Max Plus System pedestals can be installed indoors or outdoors without the need for an additional outdoor cover. The system is often the choice for garden centers and other outdoor retailers.
- **Integrated visual and audible alarms.** Built-in alarms help ensure attention to detected tags or labels.
- **Compatibility.** The Pro-Max Plus System is compatible with all 58 kHz Ultra•Max tags and labels.

Specifications

Power Supply (European)
Primary Input: 100-120Vac or 220-240Vac @ 50-60Hz
Primary Power Fuse: 2A, 250V
Current Draw: 1.5A @ 120; 1.2A @ 240
Input Power: <120W

Transmitter
Outputs: 2 ports
Operating Frequency: 58 or 60kHz (±200Hz)
Transmit Burst Duration: 1.6ms
Transmit Current: 8A peak
Burst Repetition Rate: 37.5Hz (normal) based on 50Hz ac; 45Hz (normal) based on 60Hz ac

Receiver
Inputs: 2 ports (2 antennas multiplexed)
Center Frequency: 58 or 60kHz

Alarm
Alarm Relay Output: DPDT contacts
Lamp/Audio Duration: 1-30 sec. (1 sec. increments)

Environmental
Ambient Temperature: 0° C to 50° C (32° F to 122° F)
Relative Humidity: 0-90% non-condensing

Regulatory
Safety: UL1950, Can/CSA C22.2, No. 950
EMC: 47 CRF, Part 15, ETS 300330 1994, EN 300330 1998, ETS 300683 1997, EN 61000-3-2 1995/A2: 1998, EN 61000-3-3 1995

tyco
Safety
Products

ELECTRONIC ARTICLE SURVEILLANCE



Digital Pro-Max

Max. HxWxD: 159 x 72 x 10 cm (62.5 x 28.5 x 4")
Weight: 15.4 kg (34 lbs.)

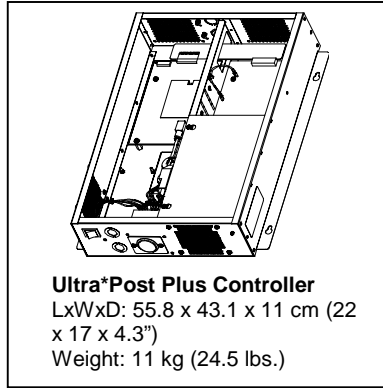

Ultra*Post Plus Controller
LxWxD: 55.8 x 43.1 x 11 cm (22 x 17 x 4.3")
Weight: 11 kg (24.5 lbs.)

Ultra*Post Plus Controller

The Ultra*Post Plus Controller provides flexibility in designing the most cost-effective, performance-driven exit solution possible. One Controller can power either:

- Two transceiver pedestals, or
- Two transmitter pedestals and two receiver antennas

Receiver antennas can be:

- Two Pro-Max Plus pedestals set in receive-only mode, or
- Two Ranger receivers, or
- Two Satellite Receivers

Pedestal alarms

Each pedestal features integrated visual and audible alarms to help ensure attention to detected tags or labels. LEDs in the top portion of the pedestal provide the visual alarm while a piezo located in the center section of the pedestal provides the audible alarm.

Feature	Function
Performance	Excellent detection in exits up to 2.4 m (7.8 ft.) wide using two pedestals.
Aesthetics	High impact plastic design ensures attractive appearance and durability.
Integrated alarms	Built-in alarm LED at the top of the pedestal.
Integrated piezo	Built-in piezo emits an audible tone alarm.
Alarm message option	External voice message unit available.
All-weather design	UL and NEMA-3R rated for outdoor use.